

LED Retrofit Proposal



Calwa
Recreation and Park District

PROPOSAL BY:



TRUE NORTH LED

INSTALLATION BY:



Electrical Contractor, License #881252

TRUE NORTH LED | Tom Fernett | 661.205.2199

tom@truenorthled.com

Executive Summary

Calwa Recreation & Park District
June 17, 2020

Option 1: Primary Technology: LED, CA Based

Overall System Investment

| | |
|--|--------------|
| Material Cost | Included |
| Labor Cost | Included |
| Recycling of Existing Fixtures in Accordance w/ CA Law | Included |
| Scissor and/or Boom Lift Rental | Included |
| System Design | Included |
| Project Management | Included |
| Rebate Administration and Acceptance as Payment* | Not Included |
| Surge Suppression | Not Included |
| Shipping | Included |
| Other Energy Conservations Measures (ECMs) | Not Included |

| | |
|--|-----------------|
| Gross Investment | \$54,563 |
| Less Rebate (Utility and/or Manufacturer) | \$0 |
| Net Investment | \$54,563 |
| Sales Tax (estimated) | \$3,038 |
| Total | \$57,601 |

Profit from Upgrade

| | |
|---|---------|
| Annual Electrical Waste Reduction: Lighting & Controls | \$5,102 |
| Annual Electrical Waste Reduction: HVAC, Source: R. Rundq | \$0 |
| Annual Maintenance Savings | \$38 |
| Rebate: Manufacturer/Instant (Expiration dates may apply, sub | \$0 |
| Rebate: Utility Company (Subject to application and approval) | \$0 |

1st Year Profit from Upgrade **\$5,140**

| | |
|---|----------------|
| Projected Annual Profit from Upgrade | \$5,140 |
| Average Monthly Profit from Upgrade | \$428 |
| Annual Kilowatt Hours Reduced | 34,014 |
| Demand Reduction, kW | - |

Financial Metrics

| | | |
|-----------------------------------|--------------|----------------|
| Return On Investment (ROI) | 9% | 10/1/25 |
| Breakeven Period in Months | 63.7 | 5/25/24 |
| Payback Period in Months | 127.4 | 9/25/29 |

10 Year Cash Flow

| | | | |
|--------|------------|---------|------------|
| Year 1 | (\$49,424) | Year 6 | (\$23,725) |
| Year 2 | (\$44,284) | Year 7 | (\$18,586) |
| Year 3 | (\$39,144) | Year 8 | (\$13,446) |
| Year 4 | (\$34,005) | Year 9 | (\$8,307) |
| Year 5 | (\$28,865) | Year 10 | (\$3,167) |

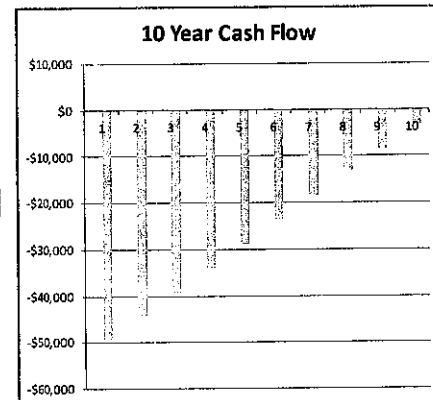
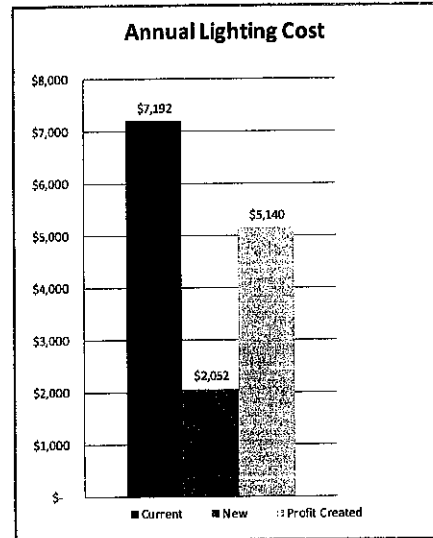

Lead Time: 4-5 Weeks or Less (Standard Products) Proposal Valid for 60 Days

Conditions

I Would Like to use Purchase Order #: _____
 I Would Like to Pay by Credit Card (check here) _____
 I Would Like a Free Cash Flow Agreement (check here) _____

50% On Order, Balance on Completion

Accepted By (print): _____ Date: _____

Signature: _____

TF

PLEASE EMAIL ACCEPTANCE TO tom@truenorthled.com

Project Data by Facility Area

Calwa Recreation & Park District
Felix Orbz

Option 1

0.15 per kWh Rate Used
Date: February 4, 2020

True North Rep: TF
Utility Co: PG&E

Exterior Lighting

| # | Facility Area Description | EXISTING | | | | PROPOSED | | | | Watts | Qty | Watts | Annual Hours | Annual kWh | Lighting kWh Saved | Controls Savings | Controls kWh Saved | Total kWh Saved | kW (demand) Saved | ANNUAL SAVINGS |
|----------------|---------------------------|----------|---------|----------|--------------|-------------------------|---------|-------------------------------|-------|-------|-----|-------|--------------|------------|--------------------|------------------|--------------------|-----------------|-------------------|----------------|
| | | Qty | Fixture | Watts | Annual Hours | New Fixture or Retrofit | Fixture | Kvlnr | Watts | | | | | | | | | | | |
| 1 | S Field | 480 | 12 | 1000w MH | 1080 | 912 | New | Linmore LL-SL1-LG-300W-50K-T3 | 5000 | 10 | 300 | 912 | 11,820 | 8,536 | 0 | 0 | 8,536 | 9.36 | \$ 1,280 | |
| 2 | NW Field | 480 | 11 | 1000w MH | 1080 | 912 | New | Linmore LL-SL1-LG-300W-50K-T3 | 5000 | 10 | 300 | 912 | 10,356 | 7,825 | 0 | 0 | 7,825 | 8.88 | \$ 1,174 | |
| 3 | NE Field | 480 | 19 | 1000w MH | 1080 | 912 | New | Linmore LL-SL1-LG-300W-50K-T3 | 5000 | 10 | 300 | 912 | 18,714 | 13,516 | 0 | 0 | 13,516 | 14.82 | \$ 2,027 | |
| 4 | SW Field | 480 | 5 | 1000w MH | 1080 | 912 | New | Linmore LL-SL1-LG-300W-50K-T3 | 5000 | 10 | 300 | 912 | 4,925 | 3,657 | 0 | 0 | 3,657 | 3.80 | \$ 534 | |
| 5 | Basketball | 480 | 12 | 100w MH | 128 | 912 | New | Linmore LL-SL1-SM-75W-50K-T3 | 5000 | 10 | 75 | 912 | 1,401 | 580 | 0 | 0 | 580 | 0.64 | \$ 87 | |
| Totals: | | | | | | | | | | | | | 47,694 | 34,014 | 0 | 34,014 | 37.30 | \$ 5,102 | | |

59

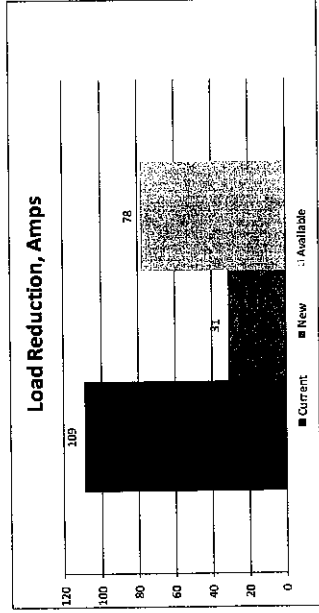

*Chart Data for Facility Areas on this Page Only

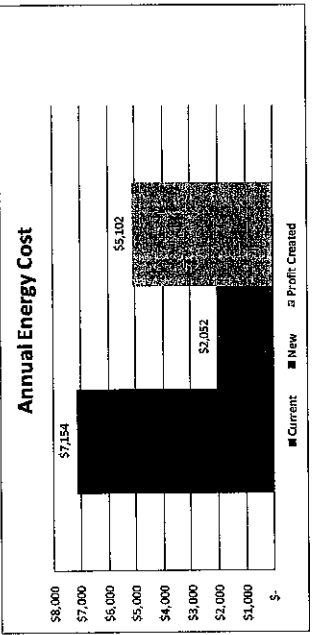

*Chart Data for Facility Areas on this Page Only

**On-Bill Financing Program (OBF)
Loan Calculation Summary Sheet
Simple project payback per meter**

Customer Name: CALWA RECREATION & PARK DISTRICT - 4545 E CHURCH

Project Number: TIF: 010950

Calculations from: Original

| (A) PROJECT COST FOR MEASURES | (B) REBATES or INCENTIVES | Customer Down Payment or Buy-Down | (C) CUSTOMER AVERAGE RATE PER kWh | (D) CUSTOMER AVERAGE RATE PER Therm | (E) ESTIMATED ANNUAL ENERGY SAVINGS (kWh) | (F) ESTIMATED ANNUAL GAS SAVINGS (Therm) | ESTIMATED ANNUAL ENERGY COST SAVINGS | SIMPLE PAYBACK IN YEARS |
|----------------------------------|------------------------------|-----------------------------------|--------------------------------------|--|--|---|--------------------------------------|-------------------------|
| \$57,601.14 | \$- | \$- | \$0.25 | \$- | 50,769.00 | - | \$12,605.05 | 4.56 |

| PAYBACK IN MONTHS BASED ON EXPECTED ENERGY SAVINGS | LOAN TERM (MONTHS) (1 month added for bill neutrality) | CUSTOMER FIXED MONTHLY LOAN PAYMENT | ESTIMATED MONTHLY ENERGY COST SAVINGS |
|--|--|-------------------------------------|---------------------------------------|
| 54 | 55 | \$1,047.29 | \$1,057.69 |

(C) = (From utility bill) Total \$ amount (12-month) / Total kWh (same 12-month)

(D) = (From utility bill) Total \$ amount (12-month) / Total therm (same 12-month)

Lumens as a Subscription Proposal Estimate*

| | |
|---------------------------|----------------------|
| Project Developer Company | True North |
| Contact Name | Tom Fernett |
| Contact Best Phone | 661-205-2199 |
| Contact Email | tom@truenorthled.com |

| | |
|----------------------------|---|
| Customer Legal Name | 0 |
| Corporate Address | 0 |
| Corporate City, State, Zip | 0 |
| Corporate Phone Number | - |
| Corporate Web Address | 0 |

| | |
|--------------------------|-------------------------------------|
| Customer Name | Calwa Recreation and Parks District |
| Project Name | 0 |
| Project Address | 0 |
| Project City, State, Zip | 0 |
| Project Description | 0 |

| | |
|-----------------------------|-----------------|
| Annual Energy Savings | \$18,998 |
| Annual Maintenance Savings | \$59 |
| Annual HVAC Savings | \$0 |
| Total Annual Savings | \$19,055 |

LINMORE LED - THE BEST KEPT SECRET LINMORELED.COM

- Companies that want to preserve cash.
- Companies that want to completely outsource lighting.
- Companies that have a portfolio of properties and want to get them all done.
- Companies that want to profit from upgrading lighting.
- Companies that don't have a capital budget for a lighting upgrade.
- Companies that want the safety, morale, and productivity from new LED Lighting in addition to the energy savings.

LINMORE LED - THE BEST KEPT SECRET LINMORELED.COM

During Subscription:

- 1 Subscription can be converted to Purchase at each anniversary date beginning at year 2
- 2 Subscription can be Transferred

End of Subscription:

- 1 Start a New Subscription Agreement with the latest LED Technology
- 2 Extend the Subscription Agreement for an additional term at a reduced monthly cost. The Extension can include upgrading, re-lamping, maintenance visits, service, and parts.
- 3 Customer takes responsibility for maintaining the system. Linmore Lighting Services will abandon the lumen supply system in place.

LaaS Prospects



Flexible Terms



Proposal Valid through June 30, 2020

| Segment 1 | |
|--|----------------|
| Term, Months | 96 |
| Months | 1-96 |
| Average Monthly Savings | \$1,785 |
| Monthly Payment (Tax not included) | \$1,677 |
| Segment 1 Average Monthly Cash Flow | \$88 |
| Segment 1 Total Cash Flow | \$8,491 |

| Segment 2 | |
|--|-----------------|
| Term, Months | 24 |
| Months | 97-120 |
| Average Monthly Savings | \$2,042 |
| Monthly Payment (Tax not included) | \$763 |
| Segment 2 Average Monthly Cash Flow | \$1,279 |
| Segment 2 Total Cash Flow | \$30,697 |

Maintenance Visits/Year: 1
 Energy Cost Inflation/Year: 3%
 Maint Cost Inflation/Year: 3%

10-Yr. Term Cash Flow \$39,187

Cash Flow Comparison Options

Option 1: Lumens as a Subscription

Option 2: Delay Upgrade

The facility will upgrade to LED now, or in the future. The total cost grows as wasted electricity, maintenance, and HVAC expenses accumulate into the future. The facility cannot stop the waste until the upgrade is integrated.

LINMORE

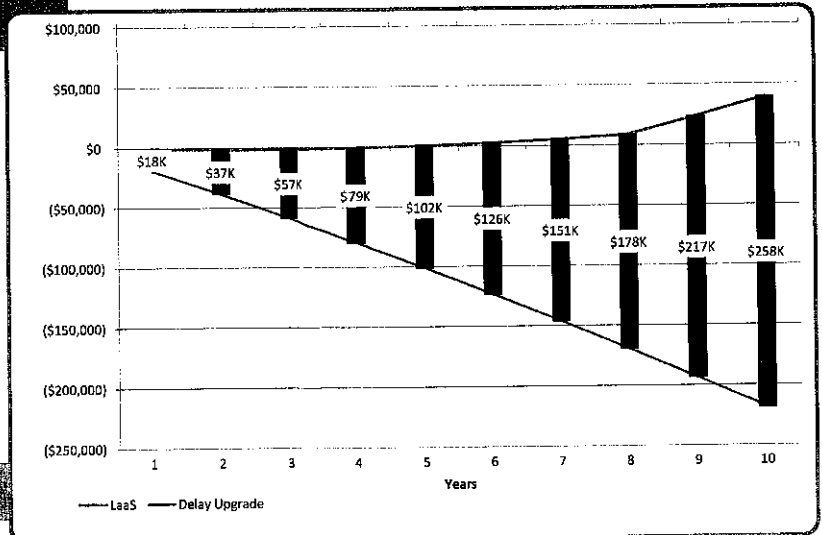

10 Year Delta between Options 1 & 2
\$257,632

* Provided as an Estimate, actual amounts upon credit approval and review of scope of work



SITE LIGHTER (SL1)

Linmore LED Labs Site Lighter (SL1) is a superior combination of performance, value, and form factor. The body of the Site Lighter is unique in that it is extruded aluminum and exceptional at moving thermal energy while the rest of the market uses castings or weldments. Beyond the thermal efficiency of the housing, the aesthetics are modern and attractive. Efficacy averages 165 lumens per watt models putting the Site Lighter in rare space ultra-low wattages to site lighting. A variety of options can direct the light where it is needed. Built to last, the Site Lighter incorporates Linmore's drivers for years of sustainable ownership. When the objective is to maximize value in your exterior lighting with power, energy savings, and aesthetics, the Linmore Site Lighter is the clear choice.

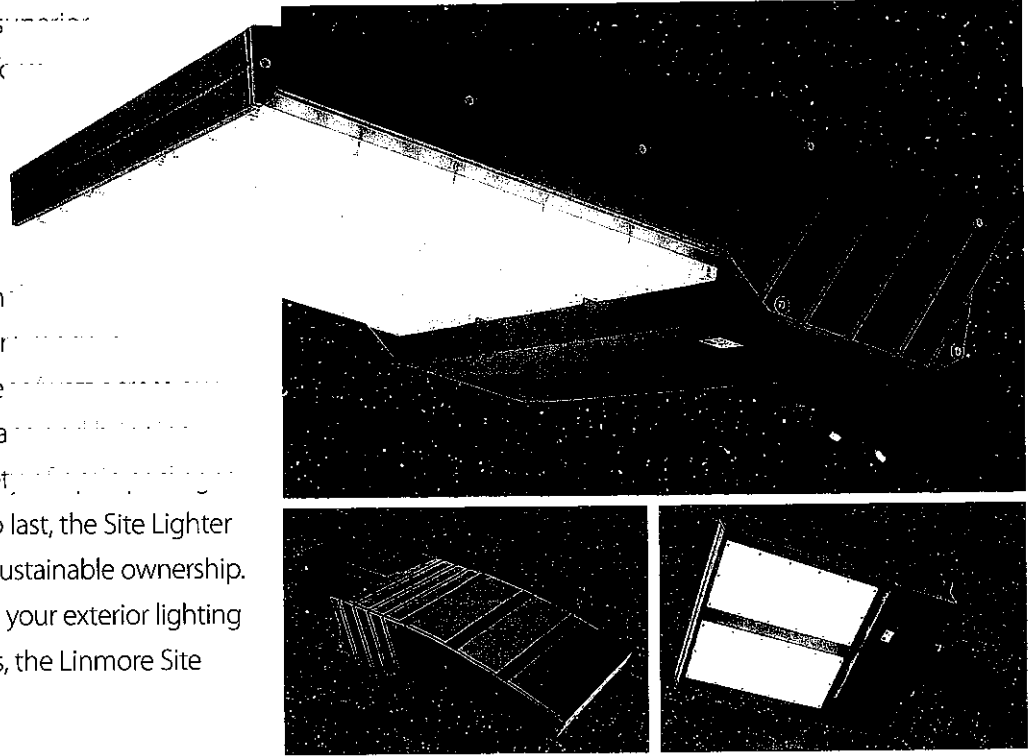

HIGHLIGHTS

Optics:

- Full Cut-Off
- Type 2, Type 3, Type 4 & Type 5
- Clear, Polycarbonate Lens
- Glare Shields

Efficacy:

- Ultra-High Efficacy-Up to 183 Lumens per Watt
- Industry Leading

Construction:

- Extruded Aluminum Body
- Heavy Duty Powder Coating
- Modern Form Factor

Controls/Sensors:

- Linmore LED Driver 0-10V Dimming
- Motion/Dimming Sensor
- Photo Cell

Bracket Options:

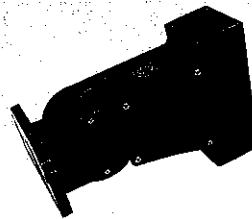

Rapid Mount Bracket
(Patent Pending)

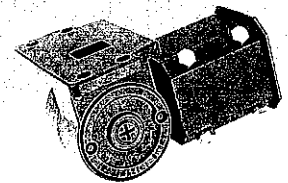

Slip Fitter
(Knuckle Adapter)

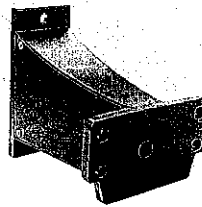

Straight Arm

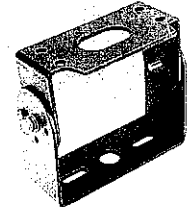

Trunnion (Yoke) Bracket

SITE LIGHTER (SL1)

Specifications

| | |
|-----------------------------|---|
| Suitability | Wet Locations-IP65 Rated |
| Warranty | 10 Years |
| Expected Life | L70- 150,000 Hours |
| System Wattages | 50W, 75W, 100W, 125W, 150W, 200W & 300W, 400W |
| Color Rendering Index (CRI) | >70 |
| Color Temperature | 2200K, 3500K, 4000K & 5000K |

| | |
|--------------------------|--|
| Operating Temperature | -40F to +130F |
| Efficacy | (5000K) Up to 183 Lumens/Watt |
| Voltage | 120-277V, 200-480V |
| Certifications | UL 1598, FCC CFR 47, Part 15, ROHS, CUL Canada, BAA/TAA Compliant, ANSI C136.31-2010 "ANS for Roadway and Area Lighting Equipment - Luminaire Vibration" |
| Design Lights Consortium | Yes |

Ordering Information

| Model | Housing Size | Wattage | Kelvin | Optic | Volts | Housing Color | Mounting | Options |
|---------|------------------|---------|-------------|-------------|-----------------|--------------------------------------|-------------------|-----------------|
| LL-SL1- | Small (SM) | 50 | 2200K (22K) | Type 2 (T2) | 120-277V (UNV) | Bronze (BRN) | Slip Fitter (SF) | FSP-201 (SN) |
| | Medium (MD) | 75 | 3500K (35K) | Type 3 (T3) | 200-480V (HV) | White (WHT) | Standard Arm (SA) | Photo Cell (PC) |
| | Large (LG) | 100 | 4000K (40K) | Type 4 (T4) | | Black (BLK) | Trunnion (TM) | |
| | Extra Large (XL) | 125 | 5000K (50K) | Type 5 (T5) | Custom (CUS)* | Slip Fitter/ Knuckle Adapter (SF) | | |
| | | 150 | | Flood (60) | * Special Order | | | |
| | 200 | | | | | | | |
| | 300 | | | | | | | |
| | 400 | | | | | | | |

Example

LL-SL1-SM-75WD-50K-T2-UNV-BRN-SF-SN

Lumen Packages

| | T2 | T3 | T4 | T5 | 60 | Housing Type | Size (WxLxH) | Weight |
|------|-------|-------|-------|-------|-------|--------------|-------------------------------|--------|
| 50W | 9897 | 9838 | 9611 | 9516 | 7000 | Small | 10.75 x 17 x 4 (taper to 1.5) | 14 |
| 75W | 13104 | 13026 | 12636 | 12558 | 10500 | Small | 10.75 x 17 x 4 (taper to 1.5) | 14 |
| 100W | 16224 | 16126 | 15600 | 16175 | 14000 | Small | 10.75 x 17 x 4 (taper to 1.5) | 14 |
| 125W | 21710 | 21493 | 20930 | 21645 | 17250 | Medium | 12.62 x 17 x 4 (taper to 1.5) | 16 |
| 150W | 25272 | 25019 | 24382 | 25196 | 20700 | Medium | 12.62 x 17 x 4 (taper to 1.5) | 16 |
| 200W | 30923 | 30745 | 32240 | 29648 | 26800 | Medium | 12.62 x 17 x 4 (taper to 1.5) | 16 |
| 300W | 47424 | 46950 | 45552 | 47282 | 40200 | Large | 20 x 17 x 4 (taper to 1.5) | 24 |
| 400W | 61000 | 61000 | 64000 | 59500 | 52000 | Extra Large | 22 x 17 x 4 (taper to 1.5) | 37 |

BUG B5-U0-G5 B4-U0-G4 B3-U0-G3 B5-U0-G5 B3-U0-G1

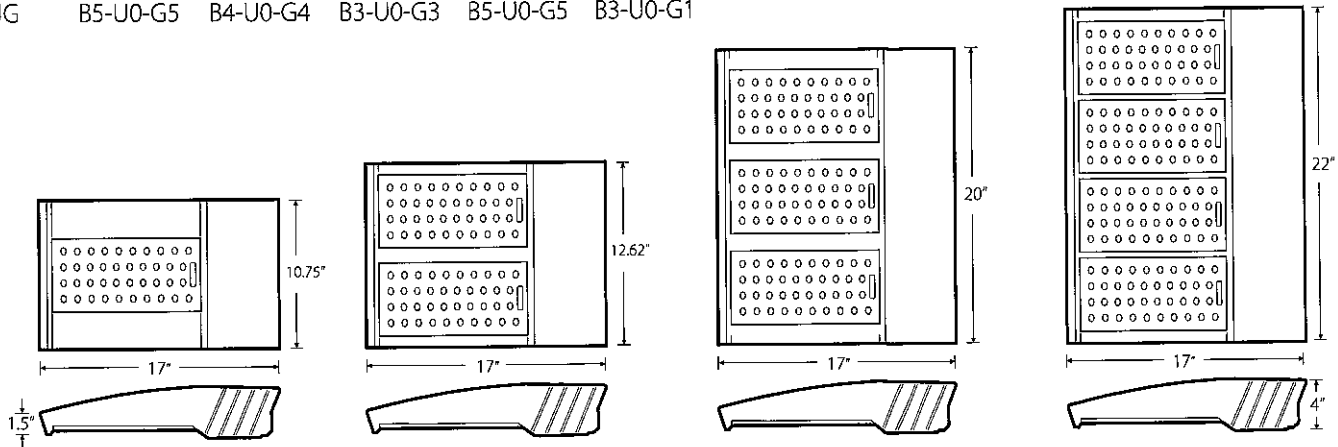

Specifications are Subject to Change.

SITE LIGHTER (SL1)

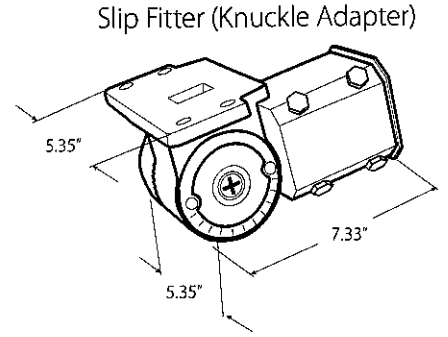
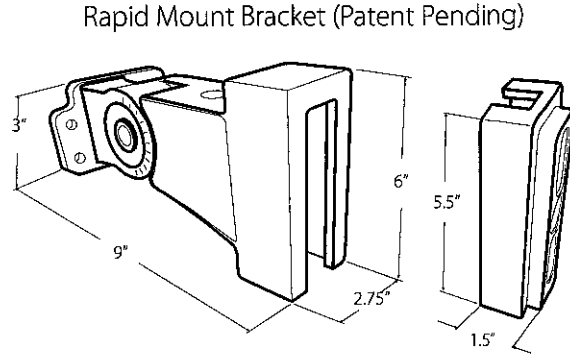
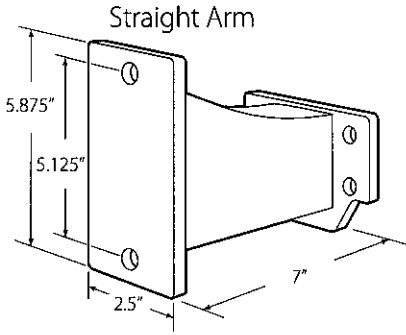

Glare Shield - Side

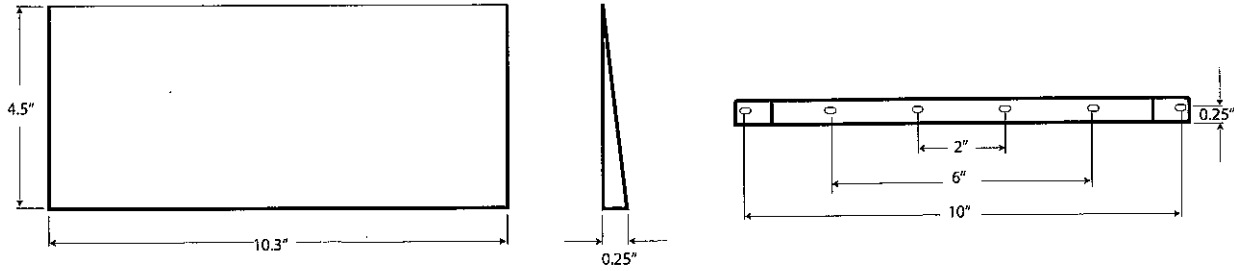

Glare Shield - Back

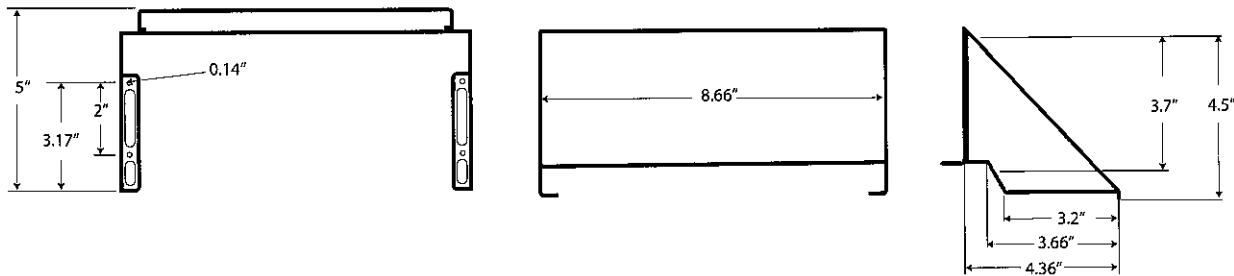

EPA Calculation

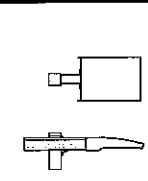
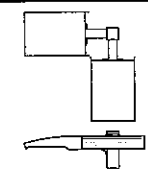
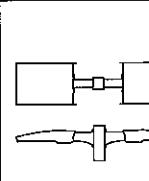
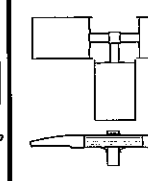
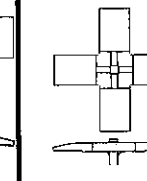
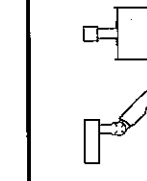
| Wattage |  |  |  |  |  |  |
|---------|---|---|---|---|---|---|
| 50W | 0.61 | 0.88 | 1.22 | 1.24 | 1.24 | 0.46 |
| 75W | 0.61 | 0.88 | 1.22 | 1.24 | 1.24 | 0.46 |
| 100W | 0.61 | 0.88 | 1.22 | 1.24 | 1.24 | 0.46 |
| 125W | 0.61 | 0.88 | 1.22 | 1.24 | 1.24 | 0.46 |
| 150W | 0.61 | 0.88 | 1.22 | 1.24 | 1.24 | 0.46 |
| 200W | 0.61 | 0.92 | 1.22 | 1.24 | 1.24 | 0.46 |
| 300W | 0.61 | 0.97 | 1.22 | 1.24 | 1.24 | 0.46 |
| 400W | 0.61 | 0.97 | 1.22 | 1.24 | 1.24 | 0.46 |

Specifications are Subject to Change.

SITE LIGHTER (SL1)

System Components

| | |
|-------------------|--|
| T2 | Type 2 Optics |
| T3 | Type 3 Optics |
| T4 | Type 4 Optics |
| T5 | Type 5 Optics |
| FR-L | Front Row Optics |
| FR-R | Front Row Optics |
| FL35 | Flood Optics 35 Degrees |
| FL60 | Flood Optics 60 Degrees |
| LL-SL1-SM-GSB | Site Lighter Glare Shield Back for use with Small Chassis (50-100w) |
| LL-SL1-MD-GSB | Site Lighter Glare Shield Back for use with Medium Chassis (125-200w) |
| LL-SL1-LG-GSB | Site Lighter Glare Shield Back for use with Large Chassis (300w) |
| LL-SL1-XL-GSB | Site Lighter Glare Shield Back for use with Extra Large Chassis (400w) |
| LL-SL2-ALL-GSS | Site Lighter Glare Shield Side for use with All Models, each |
| HV1 | High Voltage Driver, 200-480 Volt, for SL1 Fixtures up to 200 Watts, adder |
| HV2 | High Voltage Driver, 200-480 Volt, for SL1 Fixtures over 201 Watts, adder |
| SPD-277P-20KA-EC1 | 20ka Surge Suppressor |
| PC-UNV | Photocell, Button, Mounted in Side Plate, 120-277 Volt |
| PC-480V | Photocell, Twist Lock, 480 Volt |
| LL-SL1-RMB | Rapid Mount Bracket |
| LL-SL1-SA | Straight Arm Bracket |
| LL-SL1-SF | Slip Fitter Bracket |
| LL-SL1-TM | Trunion Mount Bracket |
| LL-SL1-A1 | Vertical or Horizontal Mount for Flat Surfaces |
| LL-SL1-A2 | Horizontal Mount for Round Poles |
| LL-SL1-A3 | Horizontal Wall Mount |
| LL-SL1-A4 | Vertical Wall Mount |
| LL-SL1-A10 | Single Fixture Multi-Mount Bracket |
| LL-SL1-A12 | Round to Square Pole Adapter |
| LL-SL1-A5 | Square to Vertical Slip Fitter Adapter for 4" Square Pole |
| LL-SL1-A6 | Square to Vertical Slip Fitter Adapter for 5" Square Pole |
| LL-SL1-A18 | Square to Vertical Slip Fitter Adapter for 6" Square Pole |
| LL-SL1-A7 | Round Pole to Slip Fitter Adapter for 4" Round Pole |
| LL-SL1-A14 | Round Pole to Slip Fitter Adapter for 3" Round Pole |
| LL-SL1-A17 | Slip Fitter Adapter for 4"-5" Square Poles |
| LL-SL1-A8 | Two Fixture Bullhorn |
| LL-SL1-A9 | Three Fixture Y Tenon |
| LL-SL1-A11 | Three Fixture Straight Tenon |
| LL-SL1-A13 | Four Fixture Straight Tenon |
| LL-SL1-A15 | Three Fixture T Tenon |
| LL-SL1-A16 | Two Fixture L Tenon |

A detailed Exterior Application Guide can be found at linmoreled.com/pdfs/Exterior-Application-Guide.pdf

De Lage Landen Public Finance LLC

1111 Old Eagle School Road
Wayne, PA 19087
tel 610-386-5000
www.dllgroup.com

Preliminary Proposal for Tax Exempt Lease Purchase Financing

June 23, 2020

Calwa Recreation and Park District
4545 East Church Avenue
Fresno, CA 93725

De Lage Landen Financial Services, dba De Lage Landen Public Finance LLC (“Lender”) is pleased to submit the following proposal, for discussion purposes only, based on our present understanding of the financing requirements of the Borrower named below (“Borrower”) for the acquisition of the below described capital project (“Project”). Any changes to these terms, conditions and assumptions may alter the proposed financing.

Basic Financing Structure

- This is a finance/ownership contract.
- Title to the assets being financed will be in the name of the Borrower.
- Cancellation for convenience or vendor non-performance is not permitted.
- Payment invoicing and contract servicing will be in the name of **DLL Public Finance**.

Transaction Overview

| | |
|---------------------|--|
| BORROWER: | Calwa Recreation and Park District (“Borrower”) |
| LENDER: | De Lage Landen Public Finance LLC (“Lender”) |
| VENDOR: | Waveform Electric (“Vendor”) |
| PROJECT: | LED Lighting Improvements (“Project”) |
| FINANCING TYPE: | Tax-exempt Capital Lease-Purchase Agreement, subject to annual appropriation |
| PROJECT COST: | \$127,544.00 (excludes sales tax) |
| PAYMENT FREQUENCY: | Monthly in arrears (first payment due in 30 days) |
| TERM: | 84 months |
| INTEREST RATE: | 3.37%* |
| PAYMENT FACTOR: | 0013381* |
| PAYMENT AMOUNT: | \$1,706.63* |
| NUMBER OF PAYMENTS: | 84 |

| | |
|-----------------------|--|
| CLOSING DATE: | To be determined |
| INTEREST RATE LOCK*: | The interest rate noted above is provided as an indication only and may need to be revised prior to closing. In the event that market interest rates increase prior to the date of closing (which causes an increase in the Lender's cost of funds), the interest rate shall be indexed as per the paragraph below. |
| INTEREST RATE INDEX*: | The final fixed interest rate will be determined ten (10) days prior to closing. The interest rate will be indexed to the Securities Industry and Financial Markets Association Swap/Ask Index ("SIFMA Swap Ask Yield"). |
| SALES TAXES: | Pursuant to State law, the customer may be subject to sales tax on the acquisition of the Project and related equipment purchases and improvements. If so, sales tax will be included in the amount financed. Lender will forward applicable sales taxes to the State at funding. State and/or local sales taxes are explicitly NOT the responsibility of Lender. |
| ESCROW ACCOUNT: | <p>If desired, the entire amount of the financing proceeds may be deposited on the funding date into an escrow account to be administered by an independent third party acceptable to Borrower and Lender (the "Escrow Agent") under the terms of an escrow agreement. All interest earning on the escrow fund are for the benefit of the Borrower. The fees and expenses of the Escrow Agent shall be the responsibility of the Lender.</p> <p><u>Escrow Yields:</u> The Escrow Agent administers the escrow account pursuant to the prevailing escrow agreement and relevant state law. Yields on these investments vary with market conditions. These investment arrangements are made between the Borrower and the Escrow Agent. Lender is not a party to and makes no recommendations regarding these investment decisions.</p> |
| FEES AND EXPENSES: | Lender does not charge any documentation or closing fees. Borrower is responsible for all of its own fees and expenses associated with the financing, including any and all fees and expenses incurred or required by advisors it retains. |
| TAX-EXEMPT STATUS: | This proposal is based on the Borrower's obligation in the finance agreement qualifying as a tax-exempt obligation as described in Section 103 of the Internal Revenue Code of 1986, as amended. Borrower shall be required to use the Project in a manner, and do those things required, so that the interest portions of the financing payments shall not become subject to Federal income taxation. |
| TITLE/SECURITY: | Title to the Project and all related improvements is to be held in the name of the Borrower, with Lender retaining a first priority, perfected security interest in the Project and related improvements. |
| NET FINANCING: | Maintenance, insurance and taxes on the Project will be the responsibility of the Borrower. |
| PROJECT COMPLETION: | Lender shall not be responsible for any project cost overruns or shortfalls. |

General Terms and Conditions

- This proposal is subject to credit approval.
- The interest rate indications provided herein are based upon the stated assumed transaction size. If the transaction size changes by more than 25%, DLL reserves the right to adjust the interest rates being offered.
- The interest rates, payment factors and payment amounts are subject to indexation as noted herein.
- Financing is subject to verification that all costs are eligible for inclusion in a tax exempt financing.
- If state sales tax is applicable to the sale of the Project to the Borrower, such tax is explicitly **NOT** the responsibility of Lender.
- Failure to consummate this transaction once credit approval is granted and the financing documents are drafted and delivered may result in a documentation fee being assessed to the Borrower.
- Either Lender or Borrower may terminate discussions at any time in its sole discretion.
- If made, an approval by Lender would be in a separate writing and would be subject to legal and business due diligence and credit review, with results satisfactory to Lender, in its sole discretion.
- Borrower acknowledges that the terms of the financing (if approved) may change before the parties execute final documentation.
- No financing terms will be binding on either party until definitive documentation is signed.
- This Letter is not a statement of all terms and conditions of the financing, which terms and conditions would be contained fully in final documentation and would supercede the terms of this Letter.
- This Letter is for the use of the Borrower only. No other party may derive any rights here from.
- This Letter is valid for 90 days from the date hereof and thereafter shall be deemed to be null and void.

Notwithstanding anything to the contrary, including, without limit, acceptance by Borrower, this Letter is an indication of interest regarding a possible arm's length financing transaction on the general terms and conditions outlined herein and should not be construed as a commitment to finance. The proposal contained herein consists solely of the terms under which Lender may be willing to enter into a transaction with Borrower for Lender's own account. Lender expresses no opinion and makes no representation with regard to what leasing or financing alternative is best suited for Borrower. Lender is not providing advice or recommendations with respect to the proposed transaction and has no fiduciary duty to Borrower. Borrower is encouraged to retain its own advisor.

We sincerely appreciate the opportunity to present this information.

Sincerely,

De Lage Landen Financial Services

84-125200054+0

| | | | | | | |
|-----------------------------|---|--|-------------------|---|---------------------|-------------------|
| CUSTOMER INFORMATION | Legal Entity Name (if corporation, partnership or limited liability entity please provide complete legal name) | | | | Federal Tax ID No. | |
| | Type of Business <input type="checkbox"/> Proprietorship <input type="checkbox"/> Partnership <input type="checkbox"/> Corporation <input type="checkbox"/> LLC <input type="checkbox"/> SLG <input type="checkbox"/> Non Profit <input type="checkbox"/> Fed Gov't <input type="checkbox"/> Other | | | | | |
| | State of Incorporation/Company Formation | | | Date of Incorporation/Company Formation | | |
| | Principal 1 (provide full legal name) | | | Social Security No. | | Percent Ownership |
| | Principal 2 (provide full legal name) | | | Social Security No. | | Percent Ownership |
| | Principal 3 (provide full legal name) | | | Social Security No. | | Percent Ownership |
| | Nature of Business | | Years in Business | | Number of Employees | |
| | Business Address | | | City | State | Zip |
| | Primary Applicant Contact Name | | Title | Phone | Email | |
| | <input type="checkbox"/> Check here if you own the building where the assets are going to be installed. If not, please list the legal name of the building owner. | | | | | |

| | | | | | | |
|------------------------------------|--------------------------|--|-----------------|------|--------------------|-----------------------|
| BANK AND CREDIT INFORMATION | Bank Credit Reference | | Account Officer | | Checking Acct. No. | Other Acct No. (Type) |
| | Business Address | | | City | State | Zip |
| | Secured Credit Reference | | Contact Person | | Phone Number | |

| | | | | |
|------------------------------|--|--------------|-------------|------------|
| EQUIPMENT DESCRIPTION | Equipment Description (attach quote/proposal if available) | | | |
| | Qty | Model Number | Description | Total Cost |
| | | | | |
| | | | | |
| | | | | |
| | | | | |

| | | | | |
|----------------------|--|---|-------------|-----------------|
| FINANCE TERMS | Total Finance Amount | Advanced Payment (if any) | Rate Factor | Monthly Payment |
| | Select <input type="checkbox"/> Capital Lease | Term Length Requested (months) <input type="checkbox"/> 12 <input type="checkbox"/> 24 <input type="checkbox"/> 36 <input type="checkbox"/> 48 <input type="checkbox"/> 60 | | |

You, the "Applicant" (which term includes the above business entity as well as the undersigned individual(s)), certify to us that Applicant is applying for credit for business reasons, and not for personal, family or household purposes. De Lage Landen Financial Services, Inc. and/or its assigns ("Lessor"), or its designees, is authorized to obtain information from others concerning Applicant's credit and trade standing and other relevant information impacting this Application and provide to others information about its transaction and experiences with Applicant. Lessor may obtain credit reports, including consumer credit reports, in connection with the Application, and at Applicant's request, will tell Applicant whether a credit report was obtained and, if so, the name and address of the reporting agency which provided it. Provided credit is granted, Lessor may, without further notice to Applicant, use or request subsequent credit bureau reports (1) to update Lessor's information, (2) in connection with a renewal or extension, and/or (3) in connection with Applicant's request for additional services. Applicant agrees that Lessor may get or share credit information with its agents, assignees, and its designees regarding the Applicant, Guarantor(s) or Applicant's owners in considering the Applicant's Application. Except as otherwise prohibited by law, Applicant agrees and consents that Lessor may share with affiliates and others all information about Applicant that Lessor has or may obtain for, among other things, the purpose of evaluating credit applications or offering Applicant products or services that Lessor believes may be of interest to Applicant. Applicant represents that it has reviewed this document and the information herein is true, correct and complete.

THE APPLICANT HAS A RIGHT TO A STATEMENT OF THE SPECIFIC REASONS IF AN ADVERSE ACTION HAS BEEN TAKEN. TO REQUEST THIS INFORMATION, CONTACT LESSOR'S ECOA COMPLIANCE DEPARTMENT WITHIN SIXTY (60) DAYS OF RECEIPT OF AN ADVERSE ACTION NOTIFICATION. THE DEPARTMENT CAN BE REACHED BY WRITING TO 1111 OLD EAGLE SCHOOL ROAD, WAYNE, PA 19087. WHEN CONTACTING THE DEPARTMENT, PLEASE INCLUDE A COPY OF YOUR CREDIT APPLICATION TO ASSIST US IN LOCATING YOUR FILE. LESSOR WILL PROVIDE APPLICANT WITH A STATEMENT OF THE SPECIFIC REASONS FOR THE ADVERSE ACTION WITHIN THIRTY (30) DAYS AFTER LESSOR HAS RECEIVED APPLICANT'S REQUEST.

NOTICE: THE FEDERAL EQUAL CREDIT OPPORTUNITY ACT PROHIBITS CREDITORS FROM DISCRIMINATING AGAINST CREDIT APPLICANTS ON THE BASIS OF RACE, COLOR, RELIGION, NATIONAL ORIGIN, SEX, MARITAL STATUS, AGE (PROVIDED THE APPLICANT HAS THE CAPACITY TO ENTER INTO A BINDING CONTRACT); BECAUSE ALL OR PART OF THE APPLICANT'S INCOME DERIVES FROM ANY PUBLIC ASSISTANCE PROGRAM; OR BECAUSE THE APPLICANT HAS IN GOOD FAITH EXERCISED ANY RIGHT UNDER THE CONSUMER CREDIT PROTECTION ACT. THE FEDERAL AGENCIES THAT ADMINISTER COMPLIANCE WITH THIS LAW CONCERNING THIS CREDITOR ARE THE BUREAU OF CONSUMER FINANCIAL PROTECTION, 1700 G STREET NW, WASHINGTON D.C. 20006 AND THE FEDERAL TRADE COMMISSION, EQUAL CREDIT OPPORTUNITY, WASHINGTON, D.C. 20580

APPLICANT HEREBY AUTHORIZES LESSOR OR ANY CREDIT BUREAU OR OTHER INVESTIGATIVE AGENCY EMPLOYED BY LESSOR TO INVESTIGATE THE REFERENCES HEREIN LISTED OR STATEMENTS OR OTHER DATA OBTAINED FROM APPLICANT OR FROM ANY OTHER PERSON PERTAINING TO APPLICANT'S CREDIT AND FINANCIAL RESPONSIBILITY.

Each of the undersigned is applying for joint credit.

SIGNATURE OF APPLICANT'S REPRESENTATIVE _____ TITLE _____ DATE _____

SIGNATURE OF PRINCIPAL 1 _____ TITLE _____ DATE _____

SIGNATURE OF PRINCIPAL 2 _____ TITLE _____ DATE _____

SIGNATURE OF PRINCIPAL 3 _____ TITLE _____ DATE _____

13CTG065V2

BEFORE THE BOARD OF DIRECTORS OF THE
CALWA RECREATION AND PARK DISTRICT
FRESNO COUNTY, STATE OF CALIFORNIA

Resolution Ordering Even-Year)
Board of Directors' Election, Consolidation)
of Elections, and Specifications of the)
Election Order) RESOLUTION NO. 2020 - 3

WHEREAS, the California Elections Code requires a general district election to be held in each district to choose a successor for each elective officer whose term will expire on the first Friday in December following the election to be held on the first Tuesday after the first Monday in November in each even-numbered year; and

WHEREAS, other elections may be held in whole or in part of the territory of the district and is to the advantage of the district to consolidate pursuant to Election Code 10400.

WHEREAS, Elections Code Section 10520 requires each district involved in a general election to reimburse the county for the actual costs incurred by the county elections official in conducting the election for that district; and

WHEREAS, Elections Code Section 13307 requires that before the nominating period opens the district board must determine whether a charge shall be levied against each candidate submitting a candidate's statement to be sent to the voters; determine the number of words, may estimate the cost, and state the estimate must be paid in advance; and

WHEREAS, Elections Code Section 12112 requires the election official of the principal county to publish a notice of the election once in a newspaper of general circulation in the District;

NOW, THEREFORE, IT IS ORDERED that an election be held within the territory included in this district on the **3rd day of November 2020**, for the purpose of electing members to the board of directors of said district and in accordance with the following specifications:

SPECIFICATIONS OF THE ELECTION ORDER

1. The Election shall be held on Tuesday, **the 3rd day of November 2020**. The purpose of the election is to choose members of the board of directors for the following seats:

Director Mary L. Rosales

Four-year term to expire 12/2020

Director Gabriela Mares

Four-year term to expire 12/2020

2. The District has determined that the Candidate will pay for the optional Candidate's Statement. The Candidate's Statement will be limited to 200 words. As a condition of having the Candidate's Statement published, the candidate shall pay the estimated cost at the time of filing. The District accepts the estimated cost to be determined by the County Clerk.

3. The District directs that the County Registrar of Voters of the County of Fresno publish the Notice of Election in a newspaper of general circulation that is regularly circulated in the territory.

4. This Board hereby requests and consents to the consolidation of this election with other elections which may be held in whole or in part of the territory of the district, pursuant to the Elections Code 10400.

5. The District will reimburse the County for the actual cost incurred by the county elections official in conducting the general district election upon receipt of a bill stating the amount due is determined by the elections official.

6. The Clerk of this Board is ordered to deliver copies of this Resolution, to the Registrar of Voters.

7. The Clerk of this Board is authorized to make any clerical or technical corrections to this resolution as may be requested by the county elections official.

8. THE FOREGOING RESOLUTION WAS ADOPTED upon motion of Director Raul Guerra, seconded by Director Mary L. Rosales, at a regular meeting on this day of June 16, 2020, by the following vote:

AYES: _____

NOES: _____

ABSENT: _____

ABSTAIN: _____

DATED: _____

_____, Secretary
Calwa Recreation and Park District